



Barista Hot & Iced Coffee For Your Enjoyment

JL500I series

Jetinno Commercial Bean To Cup Vending Coffee Machine

Enjoy Your Bean Go Time

Jetinno Chief Expert Counselor

JORIS HENDRIKS

Owner of 5 invention patents

Founder of Hendriks Coffee

High-end coffee machine designer

7 years in Spengler as product manager and corporate partner

15 years in Maas International as product designer and R&D manager



Joris Hendriks



CONTENTS

- Product Highlights
- Product Features
- Core Components
- Product Parameters
- Product Size
- Optional Parts
- Customization Details
- Clean Products
- Product Certificates
- Our Services



Tech Breakthrough For Better Drink Experience

Transparent Coffee Bean Grinding

Transparent bean hopper design, can see the whole process of bean grinding.

Make Iced Coffee

Built with a built-in ice maker, powerful ice making ability, empowers the machine of producing iced coffee.

High Volume Storage Space

The machine has high volume storage space design, can store barrelled water and powder, improve maintenance efficiency.





Auto cup lid capping



Drink Mixing Stick Holder

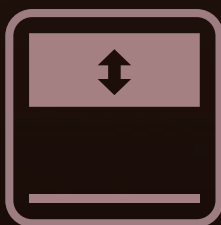

Auto Cup Door

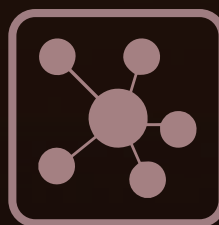

Modular design

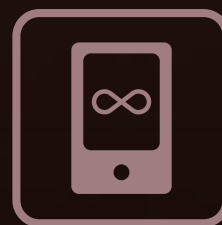

Multiple Payments



40+ drinks

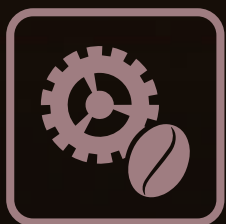

Fresh Coffee



ES Extraction



Tea drink



Touch Screen



Fast Production



Regular cleaning



Tech Breakthrough For Better Drink Experience

Transparent
bean hopper

Drinking Mixing Unit
(can hold 500
mixing sticks)



27-inch touch screen

Auto Delivery Door

High Volume Storage Space
(can store 2 barrelled water(18.9L))

Powerful Drink Production Ability

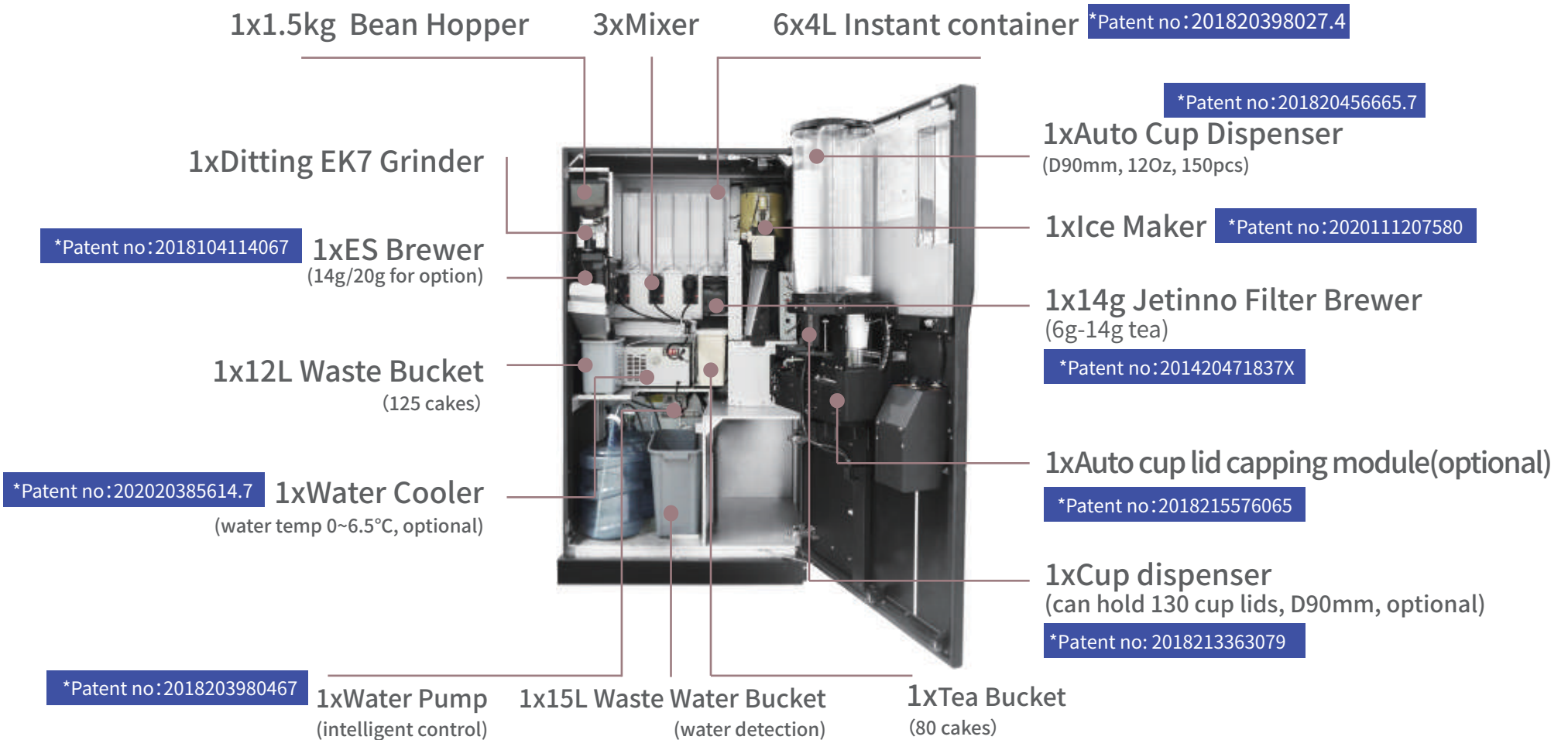



Make Over 40 Beverages

JL500I can make more than 40 beverages, mainly including fresh coffee, fresh brewed tea and instant drinks.

Make Hot, Cold & Iced Drinks

JL500I has powerful drink production ability, can make hot, cold & iced drinks, the machine can actually function as a smart drink station.



No-man Attendance, Automatic Vending

Only few touches on the screen to order drinks, user friendly interface, can adjust your selected drink flavor including sugar and milk degree. Instant production within 45 to 60 seconds, fast delivery, ease of use.

Built-in Auto Cup Transfer & Cup Lid Capping Unit

JL500I has the fully automation of producing drinks, it has a built-in cup lid capping module that can automatically cap cups.

Professionality & Craftsmanship Showed In Details



Transparent Bean Hopper
Comes with transparent bean hopper design, customers can see and feel the whole process of bean grinding. Fresh beans and fresh ground coffee.

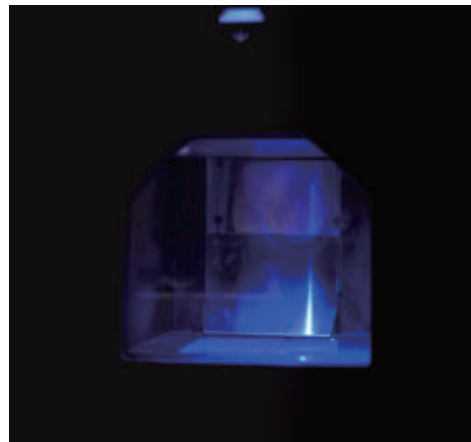

Built-in stirrer rod warehouse
convenient for consumers to quickly take out the stirrer rod and improve coffee drinking experience.



Cup Delivery Door
Designed with an automatic cup door, anti-pinch design, easy and safe to take beverages.



**High Volume Waste Bucket/
Waste Water Bucket**
Designed with high volume waste bucket and waste water bucket, has water full alert function, ease of maintenance.

Easy Use & Maintenance



Real-time Alert

When malfunctions happen, the console will push a notice.



Detachable Design

Machine's key components apply detachable design, convenient to detach and clean for deep cleaning, easy maintenance.

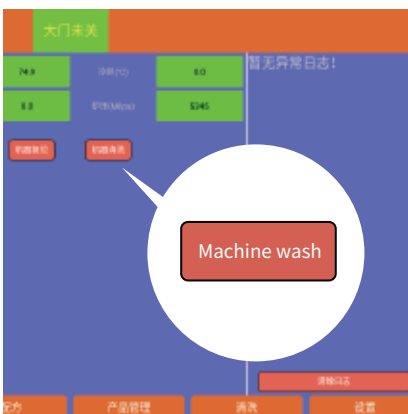

Auto Machine Self Cleaning

Designed with automatic cleaning function, the cleaning time is programmable, easy maintenance.



High Volume Waste bucket/Waste Water Bucket

Comes with high volume waste bucket and waste water bucket, has auto water full alert function.

Jetinno SaaS Management

Support PC and mobile



Remote Control

Support remote control of recipes adjustment, machine setting, UI ads and video upload, machine system upgrade.

Malfunction Alert

Real time machine malfunction alert, can push notice to machine operator.

Comprehensive Data

Location deployment data, drink sale data, payment data, all these data statistics help operator better in machine operation and coffee vending business.

Powerful Machine Console Platform

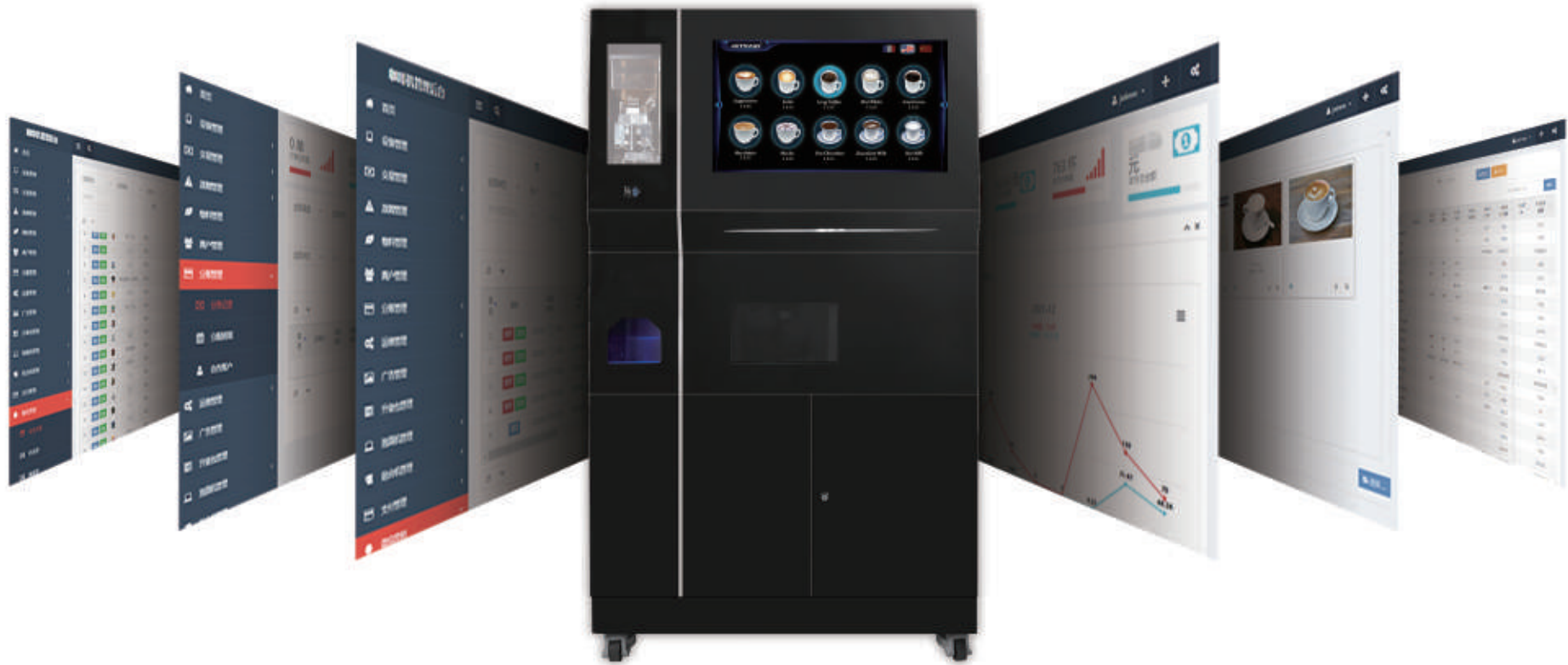

- Drink Promo Tag Setting
- Drink Sale Report

- Ads Management
- Stock Management

- Drink Data Bank

Modular Design

We have put much efforts to the modular design of JL500I, by neatly and beautifully integrating key machine components into one machine, making it more easy for operator to operate, maintain the coffee machine.

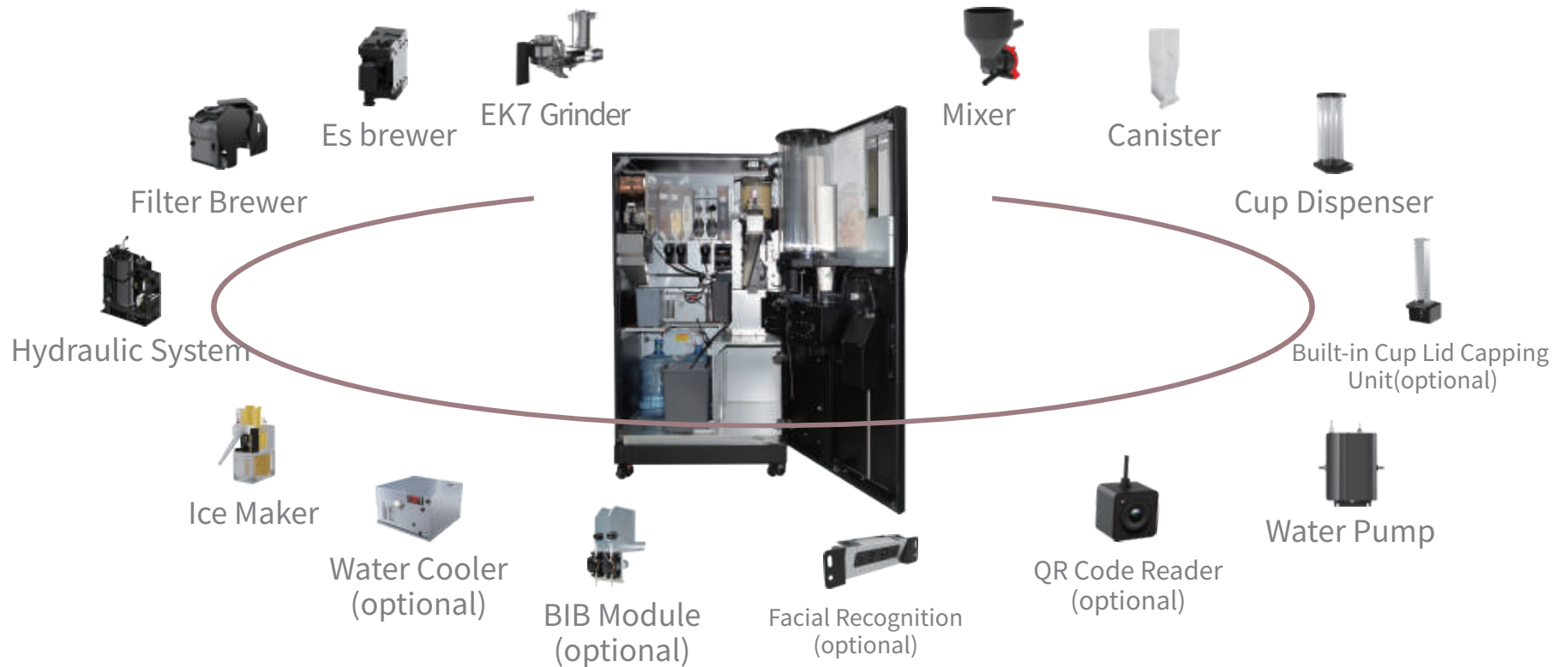



Jetinno Patented Hydraulic System

- 2700W heating power, continuous and stable water temperature guaranteed.
- Sweden Backerths 700ml stainless high-pressure boiler, max 25bar tolerance.
- USA EMERSON professional STB temperature control protective switch.
- Japan OMRON temperature/pressure sensor, real-time monitoring.
- Italy ULKA high -pressure electromagnetic pump, provides 9Bar extraction pressure.
- Other valve joints spare parts, flow meter are all Italy and German made.

Ice Maker

- Jetinno patent
- Built-in weighing device, precise control of ice production, ice empty detection.
- Brazil Embarco compressor, Japan evaporator, stable and effective.
- 1.5kg/bucket ice storage volume, daily ice production of 72kg/day
- Can manually cleaning, with UV light inside, keep hygiene.
- Intelligent detection of ice full, ice scarcity and over cooling malfunction.

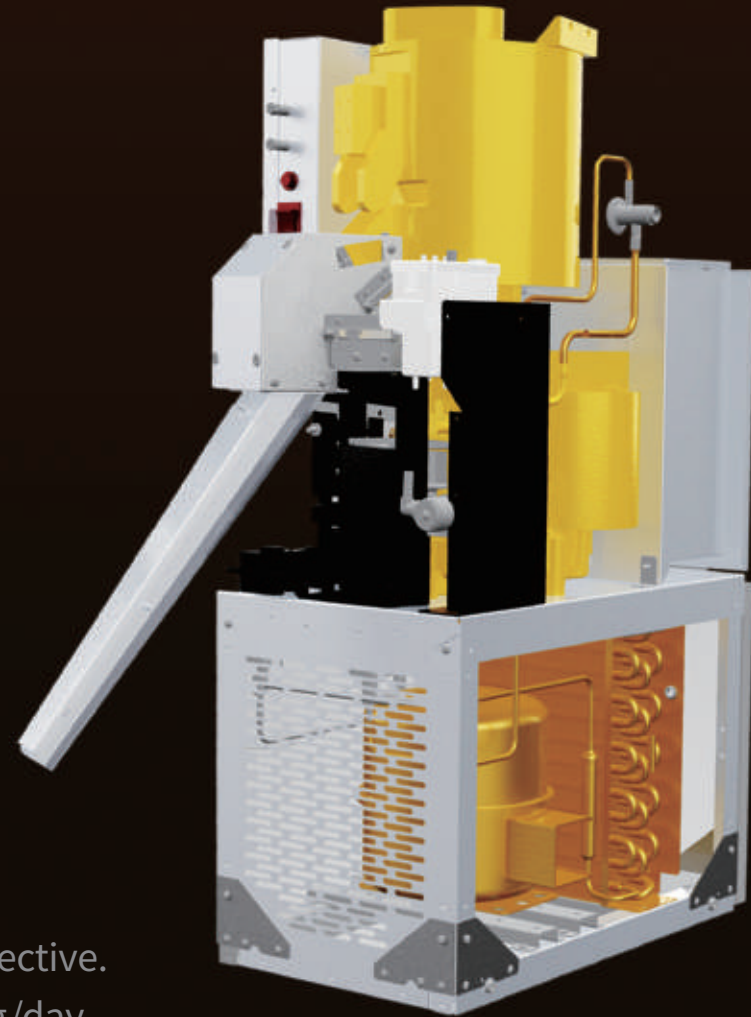

Jetinno Patented Water Cooler

- Guarantee of continuous output of cool water
- 0~6.5°C water temperature, 17mL/s cool water output speed
- Apple R134a/R600a coolant
- German instant cooling technology



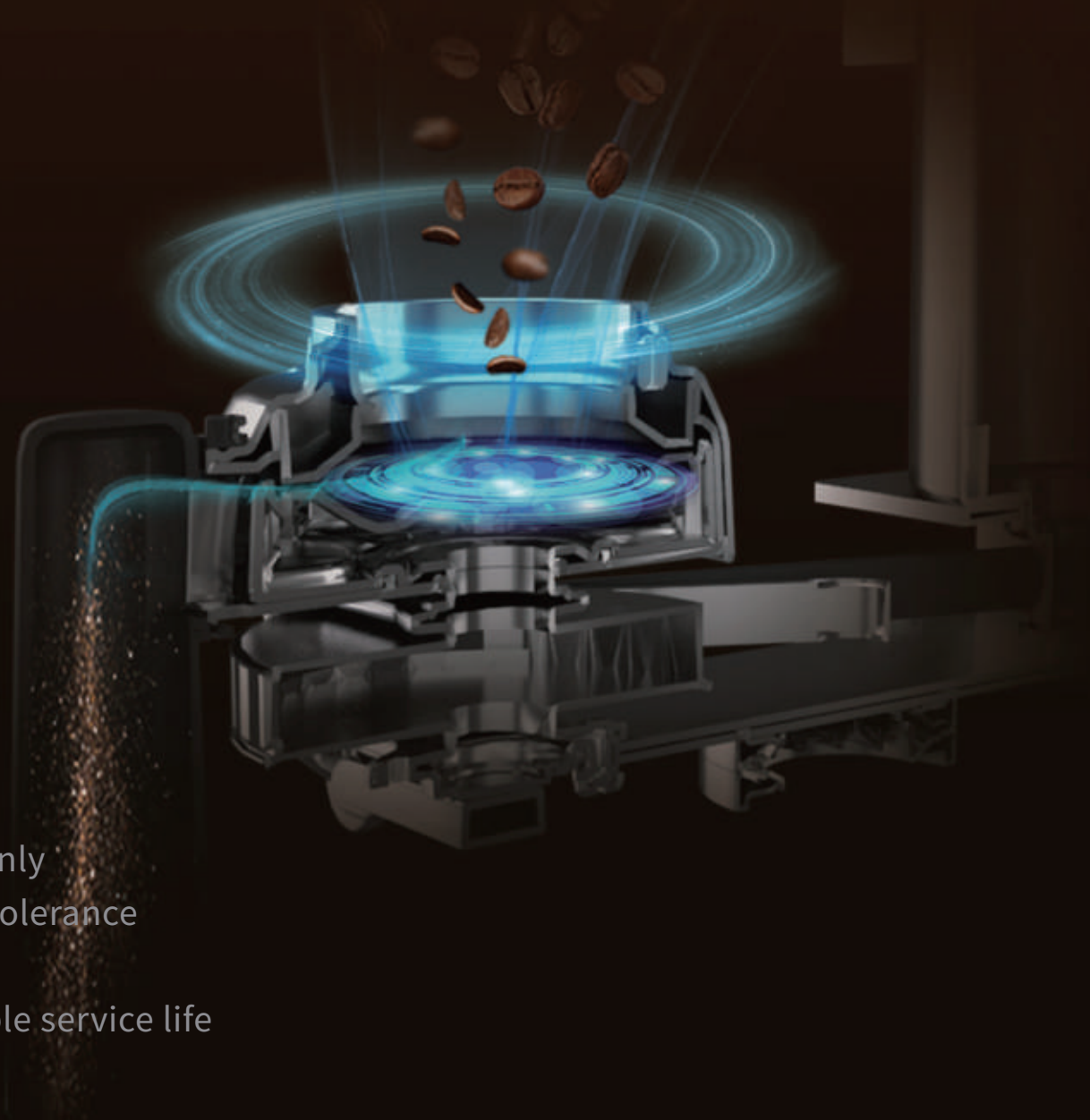

Ditting EK7 Grinder

- 64mm flat bur, can grind more evenly
- Special made blade steel, impact tolerance
- Adjustable grinding grades
- 125,000 times service life, endurable service life

PTC
Heater

Professional coffee brewing system

- Removable brewer module design, easy for cleaning.
- 9bar 92°C Espresso extraction, compatible with low-pressure brewing.
- Jetinno PTC international patent, European time-honored brand applies the same type.
- Pre-infusion function to have saturated extraction.
- PTC heaters in brewing chambers, provide constant heating to solve low-temp of first cup.
- Built with 14g and 20g two brewing chambers, for different recipes.
- Detachable brewing chamber design, easy for deep-cleaning.
- Auto decompression function to discharge residual coffee liquid.

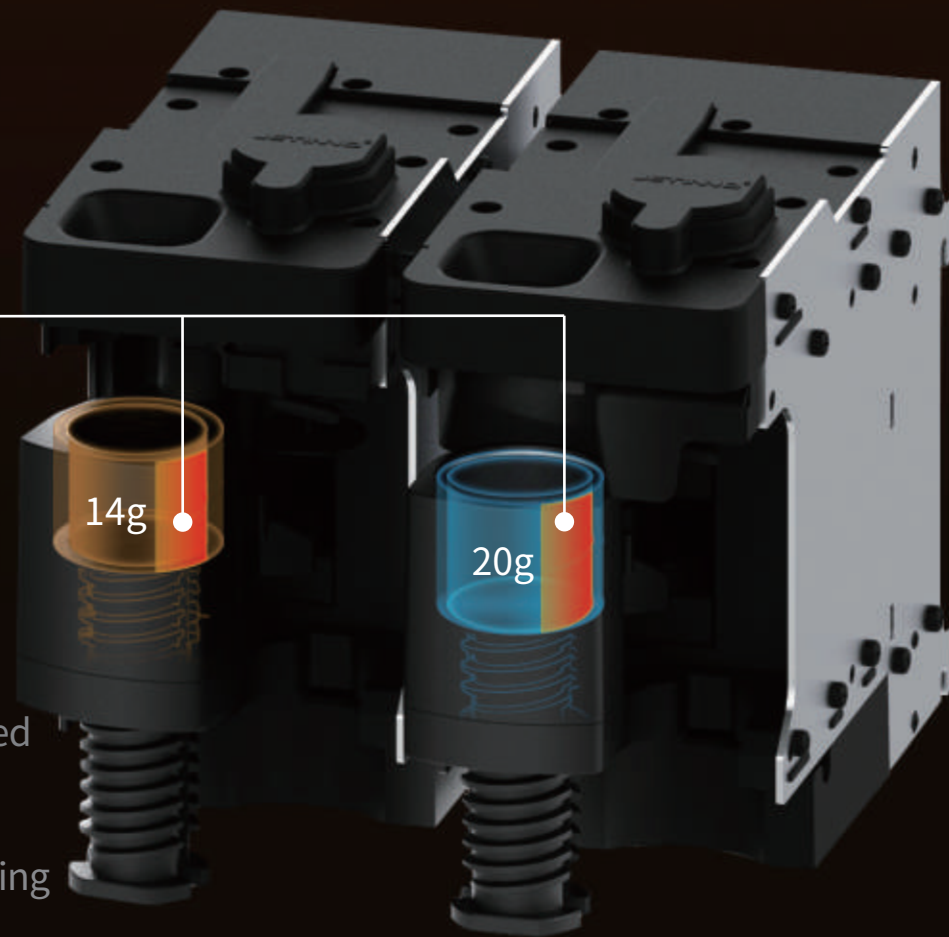



Filter Brewer(for coffee & tea)

- Jetinno patent.
- Spraying and pre-infusion, better extraction.
- Adjustable brewing time, water temperature and water dose.
- Detachable components design, convenience of cleaning.
- Direct coffee powder dropping, no secondary pollution.
- Maximum 14g coffee or tea powder loading.
- Can be used both as coffee and tea brewer.

High speed stirring system

- Patented tech innovated by Jetinno.
- Detachable stirring chamber, easy for cleaning and maintenance.
- Up to 20000rpm stirring speed, rapid sufficient dissolution.
- Adjustable stirring speed for different recipes.(milk foam requires high speed, instant coffee and tea drinks require low speed).

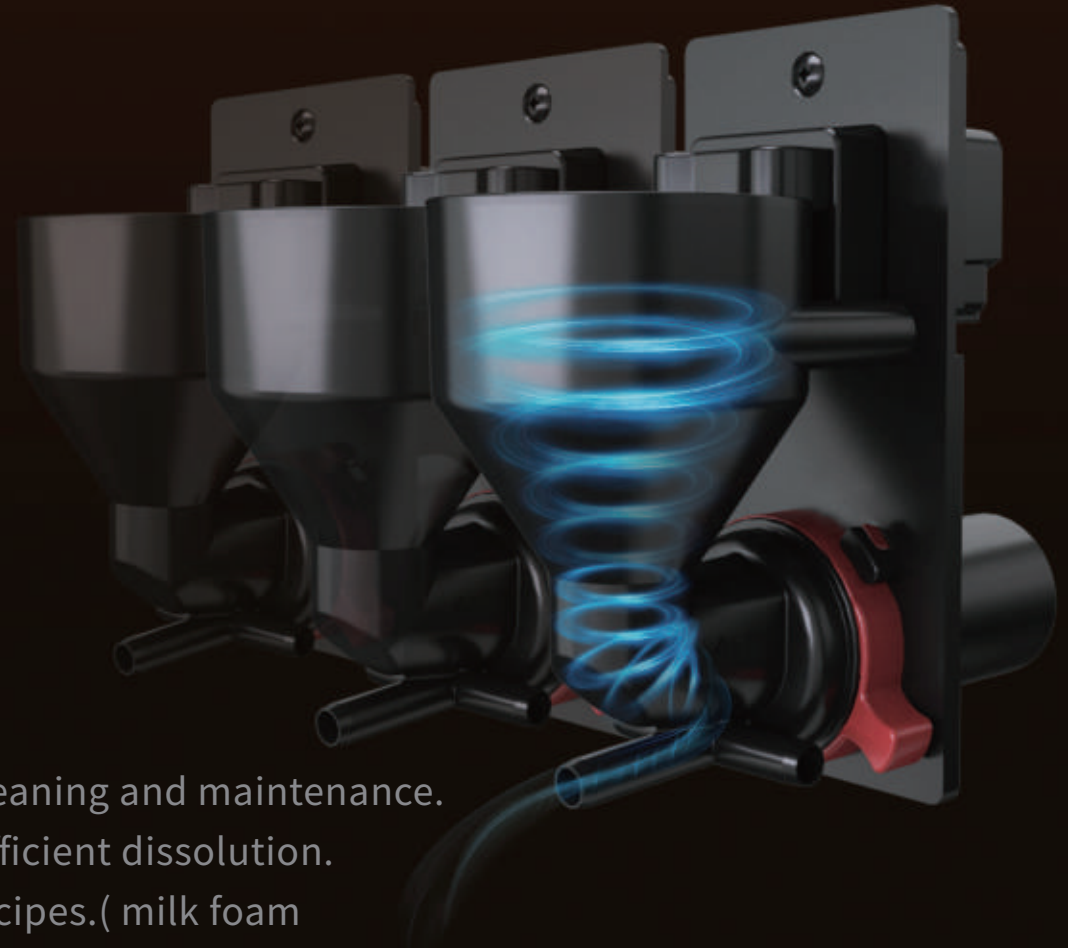



Auto Cup Transfer & Cup Lid Capping

- Jetinno patent.
- Automatic cup lid capping function.
- Intelligent monitoring of cup quantity and cup empty alert.
- Smooth cup transfer with fully automation.



Canister

- Jetinno patent.
- Detachable design, convenience of cleaning.
- Powder screw design, precise control of powder.
- Food grade plastic, HSF security certified.



Automatic Cup Dispenser

- Jetinno patent
- Auto cup & cup empty detecting, monitoring of cup quantity and status.
- 5 cup columns design, automatic column switch.
- Suitable for multiple cup size, D70/73/80/90mm (paper cup).



Two-headed Pump

- Jetinno patent
- Real-time monitoring of water, water scarcity alert.
- Noise reduction design, working noise less than 60dB.
- Auto switch of water pumping from barrelled water.



Auto Cup Dispenser

- Jetinno patent.
- Cup empty or missing alert, monitoring of cup quantity and status.
- Has 5 cup columns, automatic column switch.
- Support paper cup size of D70/73/80/90.

Multi-function main board

- Designed and developed by Jetinno.
- 8 core Cortex A7 CPU, 2GHz.
- Multiple network ports for network connection.
- Multiple displaying format ports and dual screen displaying.
- Up to 10-way ports expansion.
- Android & Linux.

IO board

- Designed and developed by Jetinno.
- Quick response.
- Fast protection for malfunctioned unit.
- Precisely control all module units.
- Multiple ports expansion, can independently support 25-way control unit.
- Support various types of sensors, including temperature, humidity, flow and pressure.





Switzerland Ditting Grinder



Italy Fluid-o-tech Pump



Sweden Backerhts boiler



German AVS Römer joints



Italy ODE valve bank



USA EMERSON switch



Configurations	JL500I-ESFB7C-PI-Y	JL500I-ES7C-PI-Y
Bean hopper	1	1
Instant container	6	6
Ditting EK7 Grinder	1	1
ES Brewer	1	1
Filter brewer	1	×
Mixer	3	4
Boiler	1	1
Gear pump	1	1
Ice Maker	√	√
Waste bin	1	1
Waste water bucket	1	1
Drip tray full detector	√	√
Auto Cup Dispenser	√	√
Cup Delivery Door	√	√
Cup lid capping module	√	√
Beverage Mixing	√	√
Water supply	Default: direct water Option: barreled water	
Internet Connection	Default: WIFI; Option: 4G	
Payment	Option: WeChat/Alipay; Nayax, or other MDB protocols	
OS	Android, Linux(Optional)	
BIB	Optional	
Chiller	Optional	
SaaS platform	Optional	
Top light box	Optional	
Color customization	Optional	

*110V (Optional)

Model Layout		JL500I-ESFB7C-PI-Y					
C7	C6	C5	C4	C3	C2	C1	
4L	4L	4L	4L	4L	4L	4L	
bean	chocolate	Milk	sugar	Mango	pineapple	Red tea	Ice Maker

*Materials in above canisters are only for reference

Configurations	Parameter specification
Operation interface	27" touch screen
Bean hopper	1x1.5kg
Instant canister	6 x 4.0L
Espresso Brewer	1x14g, 20g(Option)
Tea brewer	1x14g
Water boiler	1 x 700mL,2700W(220V)
Ice Maker	1x1.5kg/bucket
Waste bin capacity	1x125 Cakes
Waste Water Bucket	1x15L, Drip tray full detector
Auto Cup Dispenser	D90mm, 12 Oz/150Cups, 5 cup columns
Cup cover dispenser	130
Power	220-240V 50/60Hz
Rated power	2700W (230V)
Dimension (W*H*D)	1000*1855*785mm
Net weight	280kg

Main drinks: Espresso(ice/ hot), American coffee (ice/cold / hot) ,cappuccino (ice / hot), milk coffee (ice/hot) , milk (ice/hot) , cocoa (ice/hot) , Fruit juice (Ice/cold/hot), milk tea (ice/hot) , red tea (ice/hot)

Daily Output: 250 Cups/Daily

Drinks Outpt(based on protocol DIN18873-2 hourly output)

Espresso:124

American coffee :100

Cappuccino:105

Café Crème :80

*110V (Optional)

Model Layout		JL500I-ES7C-PI-Y					
C7	C6	C5	C4	C3	C2	C1	
4L	4L	4L	4L	4L	4L	4L	
Bean	Chocolate	Milk	Sugar	Mango	pineapple	matcha	Ice Maker

Beverage Mixing

Cooling water unit

Lid

*Materials in above canisters are only for reference

Configurations	Parameter specification
Operation interface	27"touch screen
Bean hopper	1x1.5kg
Instant canister	6 x 4.0L
Espresso Brewer	1x14g, 20g(Optional)
Water boiler	1 x 700mL,2700W(220V)
Ice Maker	1x1.5kg/bucket
Chiller	Optional, Water velocity17ml/s
Waste bin capacity	1x125 Cakes
Waste Water Bucket	1x15L, Drip tray full detector
Auto cup lid capping	D90mm, 12 Oz/150Cups, 5 cup columns
Cup cover dispenser	130
Power	220-240V 50/60Hz
Rated power	2700W (230V)
Dimension (W*H*D)	1000*1855*785mm
Net weight	280kg
Main drinks:Espresso(ice/ hot), American coffee (ice/cold / hot) , cappuccino (ice / hot) ,latte (Ice/hot) , mocha (Ice/hot) , milk (ice/hot) , cocoa (ice/hot) , Fruit juice (Ice/cold/hot)	

Drinks Outpt(based on protocol DIN18873-2 hourly output)

Daily Output: 250 Cups/Daily

Espresso:124	Cappuccino:105
American coffee :100	Café Crème :80

Front view

Side view

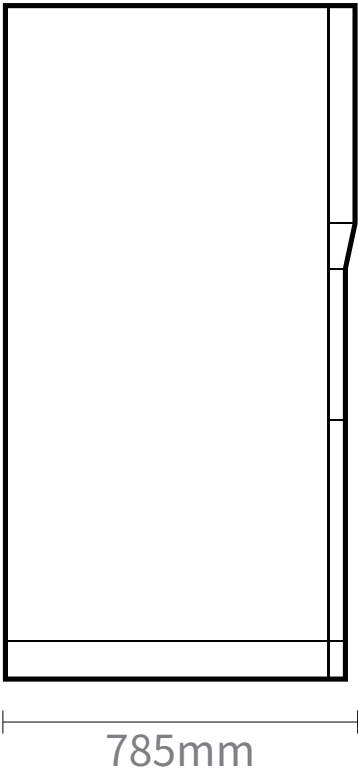
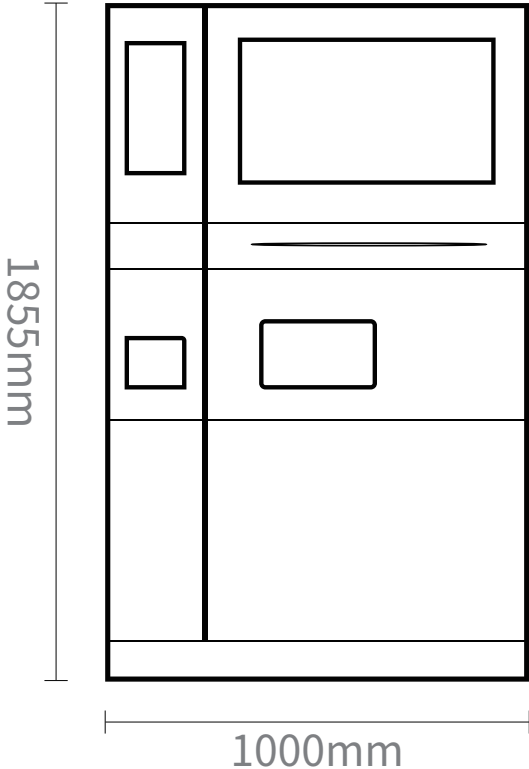

Package size: :1135 (W) *935 (D) *1920 (H) mm



Optional module	Optional or not
Jetinno Grinder	Optional
BIB peristaltic pump	Optional
Auto cup lid capping module	Optional
Human Induction	Optional
UV light	Optional
Electric meter	Optional
4G	Optional

Payment module	Optional or not
Facial scan payment	Optional
Reverse QR Code payment	Optional
Paper currency validator	Optional
Coin validator	Optional
RFID payment	Optional
MDB Cashless	Optional



BIB module

Function: connect to concentrates to make BIB drinks.

Item	Parameter
Module dimensions (W*H*D)	156x350x280mm
BIB bag weight	3kg
Port size	Dual head M30
Flow	600±10%ml/min(suction head 1 meter, pump head 0.5 meter)
Working environment	Temperature: 0~60°C Relative humidity <85%RH
Matched tube	24#
Power	32W



Jetinno grinder

Patented tech innovated by Jetinno

Item	Parameter
Rated power	230V DC , 1.0A
Grinding blade	64mm
Grinder lifetime	500-1000kg
Grinder speed	1.4-1.7g/s
Grinder lifetime	150000
Adjustable coffee ground fineness, easy to use.	

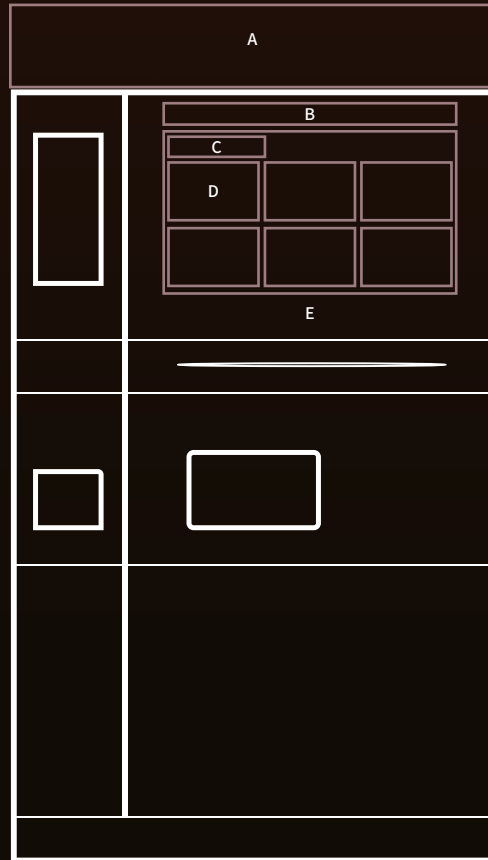

UI customization

Name	Position	Width	Height	Format
Light box	A	1000mm	<300mm	AI or cdr
Brand LOGO	B	<600mm	<70mm	AI or cdr
UI LOGO	C	327PX	66PX	PNG
UI drink picture	D	287PX	287PX	PNG
Video ads	E	1920PX	1080PX	MP4

Deep customization

Name	Item
Ports	Open underlying control serial port protocol, support customer self-developed APP.
	Open network interface(TCP/IP), support customer self-developed server.
	Open RESTful interface, support customer online store and data system.
OS	APP application layer customizable development (Linux, Android).



Product: Coffee machine tea brewer cleaner
 Use: used for coffee machine tea brewer cleaning
 Ratio: 2 pills with 5.67L water
 Details: 4g/pill, 120 pills/bottle, 12 bottles/case



Product: coffee machine boiler cleaner
 Use: used for coffee machine boiler cleaning
 Ratio: 200g powder with 3.9L water
 Details: 1kg/bottle, 6 bottles/case



Product: coffee machine cleaner
 Use: used for coffee machine brewer cleaning
 Details: 2g/pill, 100 pills/can, 12 cans/case



Product: cleaning brush
 Use: used for coffee machine cleaning and maintenance
 Details : general use



Product: tower
 Use: used for coffee machine cleaning and maintenance
 Details : general use



Security Certification



Food Contact Material

EU 1935/2004
European food test

Europe

LFGB
German



US

GB
GB4806
China

Europe EVA energy consumption level A

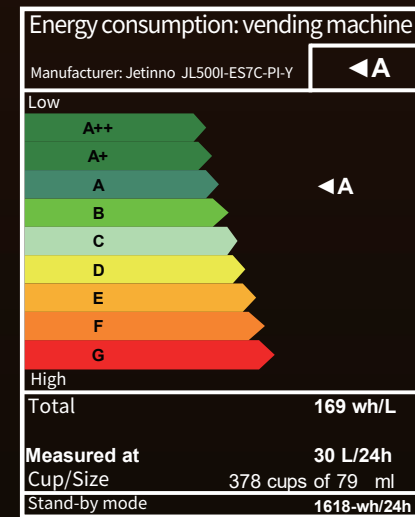

95% Recycled

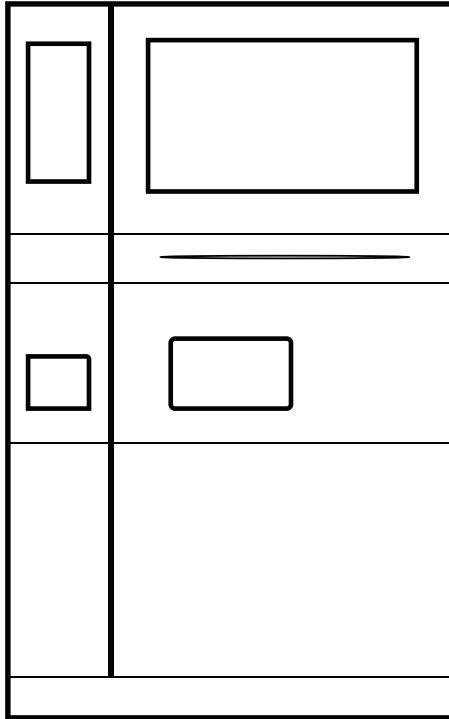

Guangzhou Jetinno Intelligent Equipment Co., Ltd

Address: 4F, No. 2, Ruitai Road, Huangpu District, Guangzhou, China

Tel: 400-017-9997

E-mail: inquiry@jetinno.com

Website: www.jetinno.com

www.jetinnovending.com